

Variable Gain Photoreceiver - Fast Optical Power Meter

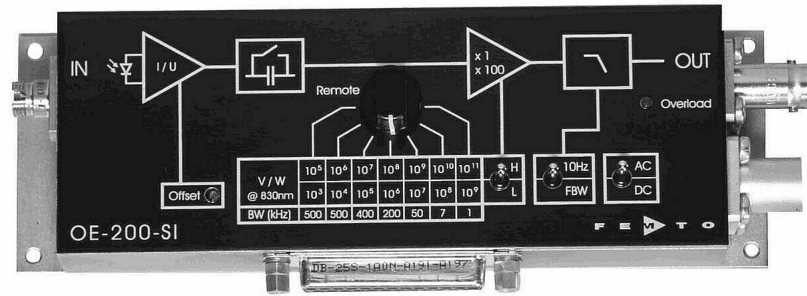

Features

- Conversion Gain Switchable from 1×10^3 to 1×10^{11} V/W
- Si PIN Detector with 1.2 mm Active Diameter
- Fiber Optic or Free Space Input
- Spectral Range 320 - 1060 nm
- Calibrated at 830 nm (Fiber Optic Versions Only)
- Bandwidth up to 500 kHz
- Local and Remote Control

Applications

- Fast Fiber Optic Power Meter
- Spectroscopy
- General Purpose Opto-Electronic Measurements
- Optical Receiver for Use with Lock-In Amplifiers

Block Diagram

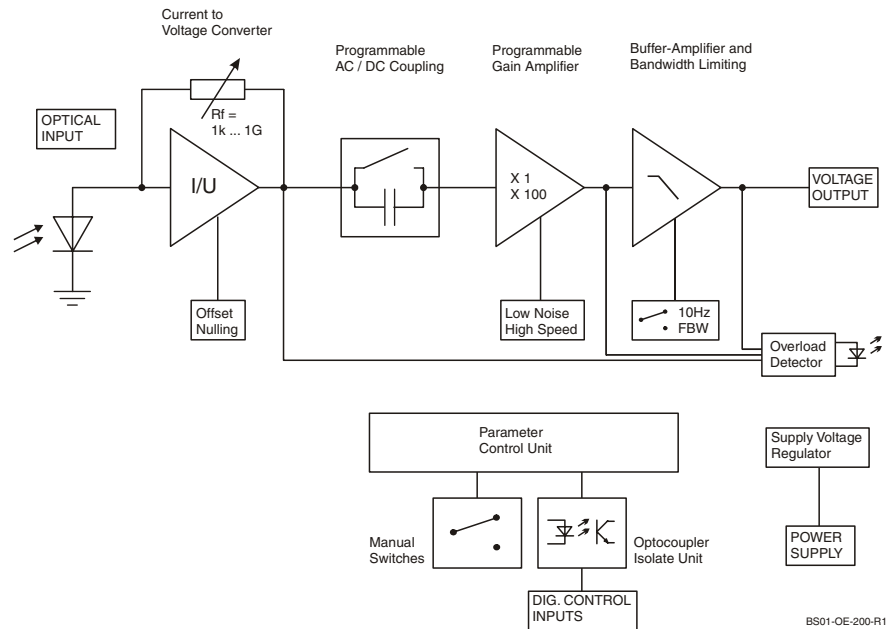

BS01-OE-200-R1

Variable Gain Photoreceiver - Fast Optical Power Meter

Specifications	<i>Test Conditions</i>	<i>V_s = ± 15 V, T_a = 25°C</i>						
Gain	Conversion Gain	1 x 10 ³ ... 1 x 10 ¹¹ V/W (@ 830 nm)						
	Gain Accuracy	± 1 % electrical, between settings						
	Conversion Gain Accuracy (P _{opt} ≤ 1 mW, @ 830 nm)	OE-200-SI-FS:	± 15 % electro optical					
	Gain Drift	OE-200-SI-FC/-SMA:	± 5 % electro optical see table below					
Frequency Response	Lower Cut-Off Frequency	DC / 1 Hz, switchable						
	Upper Cut-Off Frequency	up to 500 kHz (see table below), switchable to 10 Hz						
	Gain Flatness	± 0.1 dB						
Input	Noise Equivalent Power (NEP)	see table below						
	Max. CW Saturation Power	see table below						
	Offset Current Compensation	± 600 pA, adjustable by offset trimpot or ± 400 pA, adjustable by external control voltage						
Detector	Detector	Si PIN photodiode						
	Active Area	Ø 1.2 mm						
	Spectral Response	320 – 1060 nm						
	Sensitivity	0.6 A/W (@ 830 nm)						
	Dark Current	2 pA typ.						
Performance Depending on Gain Setting	Gain Setting (Low Noise) (V/W)	10 ³	10 ⁴	10 ⁵	10 ⁶	10 ⁷	10 ⁸	10 ⁹
	Upper Cut-Off Frequency (- 3 dB)	500 kHz	500 kHz	400 kHz	200 kHz	50 kHz	7 kHz	1.1 kHz
	Rise / Fall Time (10% - 90%)	700 ns	700 ns	900 ns	1.8 µs	7 µs	50 µs	300 µs
	NEP (√Hz, 830 nm)	33 pW	3.8 pW	800 fW	240 fW	80 fW	24 fW	10 fW
	measured at	10 kHz	10 kHz	10 kHz	1 kHz	1 kHz	100 Hz	100 Hz
	Integr. Input Noise (rms)*	39 nW	5 nW	1.3 nW	400 pW	130 pW	17 pW	2.5 pW
	Input Offset Drift (°C)	60 nW	6 nW	0.6 nW	51 pW	5.1 pW	0.8 pW	0.6 pW
	Gain Drift (°C)	0.008%	0.008%	0.008%	0.01%	0.01%	0.01%	0.02%
	CW Saturation Power	2 mW	1 mW	0.1 mW	10 µW	1 µW	0.1 µW	10 nW
	Gain Setting (High Speed) (V/W)	10 ⁵	10 ⁶	10 ⁷	10 ⁸	10 ⁹	10 ¹⁰	10 ¹¹
	Upper Cut-Off Frequency (- 3 dB)	500 kHz	500 kHz	400 kHz	200 kHz	50 kHz	7 kHz	1.1 kHz
	Rise / Fall Time (10% - 90%)	700 ns	700 ns	900 ns	1.8 µs	7 µs	50 µs	300 µs
	NEP (√Hz, 830 nm)	25 pW	3.5 pW	800 fW	240 fW	80 fW	24 fW	10 fW
	measured at	10 kHz	10 kHz	10 kHz	1 kHz	1 kHz	100 Hz	100 Hz
	Integr. Input Noise (rms)*	24 nW	3.7 nW	1.1 nW	350 pW	110 pW	16 pW	2.3 pW
	Input Offset Drift (°C)	60 nW	6 nW	0.6 nW	51 pW	5.1 pW	0.8 pW	0.6 pW
	Gain Drift (°C)	0.008%	0.008%	0.008%	0.01%	0.01%	0.01%	0.02%
	CW Saturation Power	0.1 mW	10 µW	1 µW	0.1 µW	10 nW	1 nW	0.1 nW

* The integrated input noise is measured with a shaded input in the full bandwidth („FBW“) setting. The input referred peak-peak noise can be calculated from the rms noise as follows:

$$P_{\text{Input Noise peak peak}} = P_{\text{Input Noise rms}} \times 6$$

The output noise is given by:

$$U_{\text{Output Noise rms}} = P_{\text{Input Noise rms}} \times \text{Gain}$$

$$U_{\text{Output Noise peak peak}} = U_{\text{Output Noise rms}} \times 6 = P_{\text{Input Noise rms}} \times \text{Gain} \times 6$$

The integrated noise will be reduced considerably by setting the low pass filter to “10 Hz” instead of “FBW”. This is especially useful for continuous wave (cw) measurements.

Variable Gain Photoreceiver - Fast Optical Power Meter

Specifications (continued)		
Output	Output Voltage Range Output Impedance Max. Output Current	± 10 V (@ ≥ 1 M Ω load) 50 Ω (terminate with ≥ 1 M Ω load for best performance) ± 30 mA
Indicator LED	Function	overload
Digital Control	Control Input Voltage Range Control Input Current Overload Output	LOW bit: - 0.8 ... + 1.2 V, HIGH bit: + 2.3 ... + 12 V 0 mA @ 0 V, 1.5 mA @ + 5 V, 4.5 mA @ + 12 V non active: 0 V, max. - 1 mA, active: 5.1 V, max. 7 mA
Ext. Offset Control	Control Voltage Range Offset Control Input Impedance Conversion Factor	± 10 V 20 k Ω 40 pA/V
Power Supply	Supply Voltage Supply Current Stabilized Power Supply Output	± 15 V + 110 / - 80 mA (depends on operating conditions, recommended power supply capability minimum ± 200 mA) ± 12 V, max. 150 mA, + 5 V, max. 50 mA
Case	Weight Material	320 g (0.74 lb.) AlMg4.5Mn, nickel-plated
Temperature Range	Storage Temperature Operating Temperature	- 40 ... + 80 $^{\circ}$ C 0 ... + 60 $^{\circ}$ C
Absolute Maximum Ratings	Max. CW Power (Averaged) Digital Control Input Voltage Analog Control Input Voltage Power Supply Voltage	20 mW - 5 V / + 16 V relative to digital ground DGND (pin 9) ± 15 V relative to analog ground AGND (pin 3) ± 22 V

Variable Gain Photoreceiver - Fast Optical Power Meter

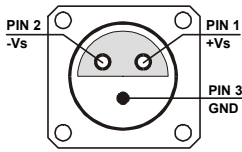
Connectors	<p>Input</p> <p style="margin-left: 20px;">OE-200-SI-FS 25 mm round flange for free space applications</p> <p style="margin-left: 20px;">OE-200-SI-FC FC fiber optic receptacle</p> <p style="margin-left: 20px;">OE-200-SI-SMA SMA fiber optic receptacle</p> <p>Output</p> <p style="margin-left: 20px;">BNC</p> <p>Power Supply</p> <p style="margin-left: 20px;">LEMO series 1S, 3-pin fixed socket</p> <p style="margin-left: 20px;">Pin 1: + 15 V</p> <p style="margin-left: 20px;">Pin 2: - 15 V</p> <p style="margin-left: 20px;">Pin 3: GND</p>
	<div style="text-align: center;">  </div> <p>Control Port</p> <p style="margin-left: 20px;">Sub-D 25-pin, female, qual. class 2</p> <p style="margin-left: 20px;">Pin 1: + 12 V (stabilized power supply output)</p> <p style="margin-left: 20px;">Pin 2: - 12 V (stabilized power supply output)</p> <p style="margin-left: 20px;">Pin 3: AGND (analog ground for pins 1 - 8)</p> <p style="margin-left: 20px;">Pin 4: + 5 V (stabilized power supply output)</p> <p style="margin-left: 20px;">Pin 5: status output: HIGH = overload</p> <p style="margin-left: 20px;">Pin 6: signal output (connected to BNC)</p> <p style="margin-left: 20px;">Pin 7: NC</p> <p style="margin-left: 20px;">Pin 8: input offset control voltage</p> <p style="margin-left: 20px;">Pin 9: DGND (ground for digital control pins 10 - 14)</p> <p style="margin-left: 20px;">Pin 10: digital control input: gain, LSB</p> <p style="margin-left: 20px;">Pin 11: digital control input: gain</p> <p style="margin-left: 20px;">Pin 12: digital control input: gain, MSB</p> <p style="margin-left: 20px;">Pin 13: digital control input: AC/DC</p> <p style="margin-left: 20px;">Pin 14: digital control input: high speed / low noise</p> <p style="margin-left: 20px;">Pin 15 - 25: NC</p>
Available Models	<p>OE-200-SI-FS free space input, no calibration</p> <p>OE-200-SI-FC FC receptacle, calibrated at 830 nm</p> <p>OE-200-SI-SMA SMA receptacle, calibrated at 830 nm</p> <p>OE-200-S customized versions available on request</p>

Variable Gain Photoreceiver - Fast Optical Power Meter

Remote Control Operation

General

Remote control input bits are opto-isolated and connected by a logical OR function to the local switch settings. For remote control set the corresponding local switches to "Remote", "AC" and "H" and select the desired setting via a bit code at the corresponding digital inputs. Mixed operation, e.g. local AC/DC setting and remote controlled gain setting, is also possible.

The switch setting "FBW / 10 Hz" of the low pass signal filter is not remote controllable.

Gain Setting

Low Noise Gain (V/W) Pin 14=HIGH	High Speed Gain (V/W) Pin 14=LOW	Pin 12 MSB	Pin 11	Pin 10 LSB
10^3	10^5	LOW	LOW	LOW
10^4	10^6	LOW	LOW	HIGH
10^5	10^7	LOW	HIGH	LOW
10^6	10^8	LOW	HIGH	HIGH
10^7	10^9	HIGH	LOW	LOW
10^8	10^{10}	HIGH	LOW	HIGH
10^9	10^{11}	HIGH	HIGH	LOW

AC/DC Setting

Coupling	Pin 13
AC	LOW
DC	HIGH

Spectral Response

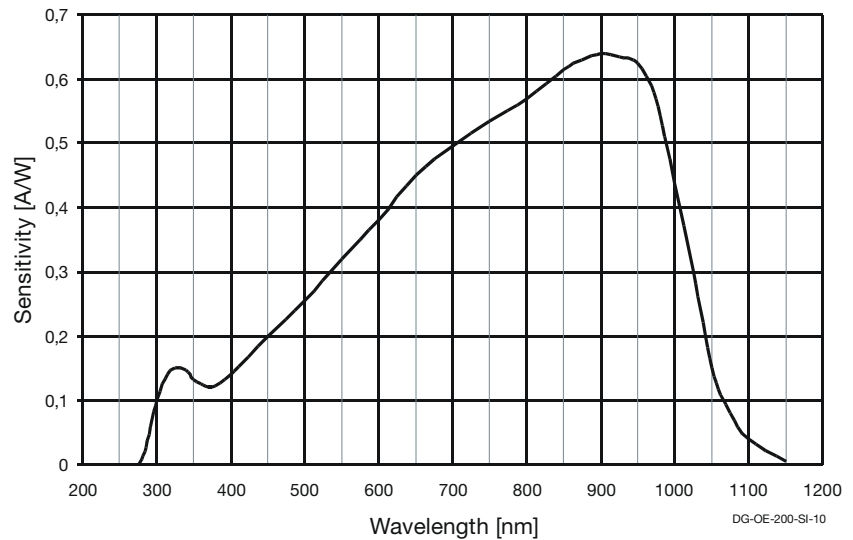

Variable Gain Photoreceiver - Fast Optical Power Meter

Dimensions

Free Space Input OE-200-SI-FS:

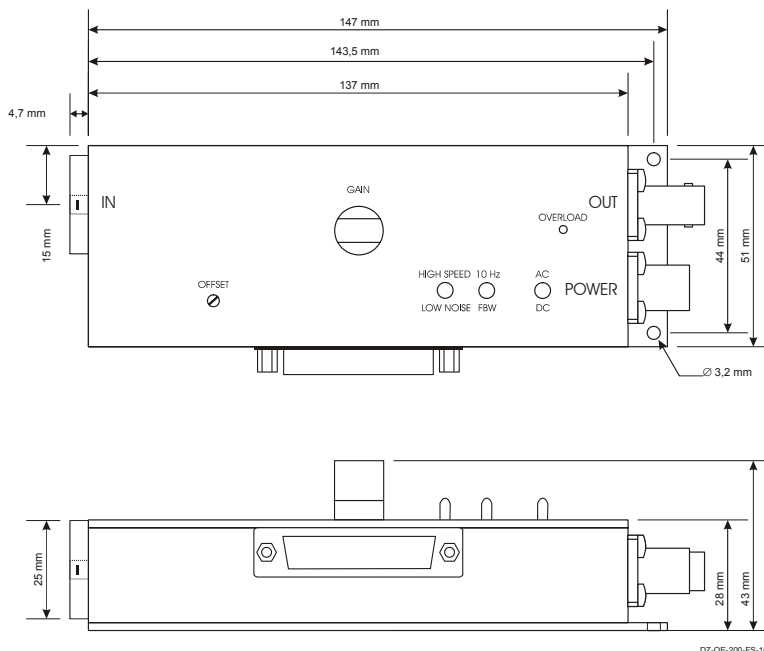

DZ-OE-200-FS-10

Fiber Optic Input OE-200-SI-FC and OE-200-SI-SMA:

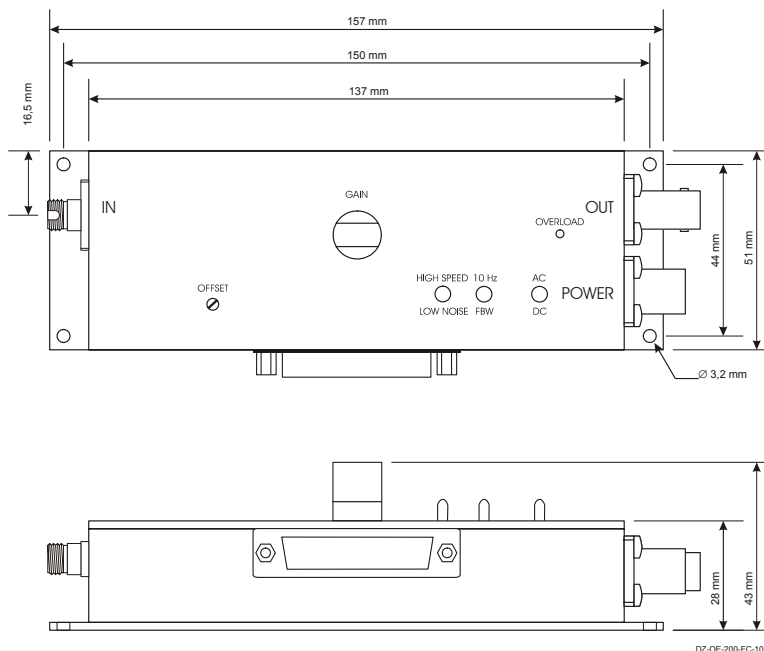

DZ-OE-200-FC-10

FEMTO Messtechnik GmbH
 Klosterstr. 64
 D-10179 Berlin · Germany
 Tel.: +49-(0)30-280 4711-0
 Fax: +49-(0)30-280 4711-11
 e-mail: info@femto.de
 http://www.femto.de

Specifications are subject to change without notice. Information furnished herein is believed to be accurate and reliable. However, no responsibility is assumed by FEMTO Messtechnik GmbH for its use, nor for any infringement of patents or other rights granted by implication or otherwise under any patent rights of FEMTO Messtechnik GmbH. Product names mentioned may also be trademarks used here for identification purposes only.
 © by FEMTO Messtechnik GmbH
 Printed in Germany